

General Warning

Snowmobiles are capable of traveling at very high speeds and can be hazardous to operate. Not maintaining or inspecting your snowmobile on a regular basis can be even more dangerous. Riders should always wear protective clothing and a full-faced helmet. Read these directions completely and thoroughly before installing and riding with your HRP Ice Scratchers. Failure to follow these installation instructions carefully, to observe these **WARNINGS**, or to ride cautiously and within your abilities could cause unexpected failure of your HRP Ice Scratchers or other parts of your snowmobile, or could cause you to lose control of your snowmobile and crash, resulting in serious injury or death. Installation of any component or kit should only be performed by persons experienced in the installation and proper operation of snowmobile parts. It is also the responsibility of the person installing any part or kit to determine the suitability of the part or kit for that particular application.

General Installation Instructions for Ice Scratchers – HRP 8001

Polaris RMK

04-06 Ski-Doo Summit/Summit Rev

1. Remove front set of idler wheels
2. Drill upper idler wheel mount hole to 3/8".
3. Drill a second hole 2 1/4" forward with a 9/32" drill.
4. Install ice scratchers using supplied hardware.

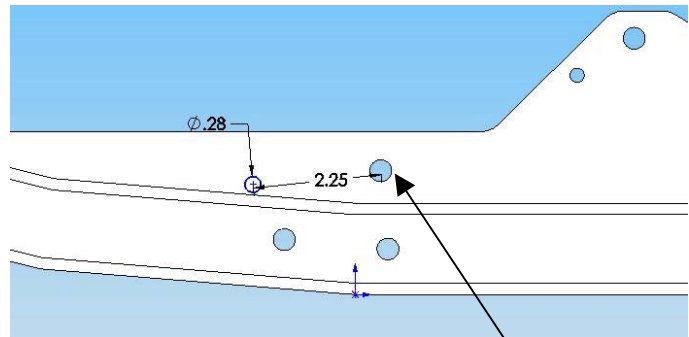

Drill existing hole out to 3/8"

Arctic Cat 1M Series

1. Drill rear idler wheel hole out to 3/8"
2. Drill a second hole 2 1/4" forward of the first enlarged hole with a 9/32" drill. The hole should be slightly above the rail strengthening rib.
3. Install ice scratchers using supplied hardware

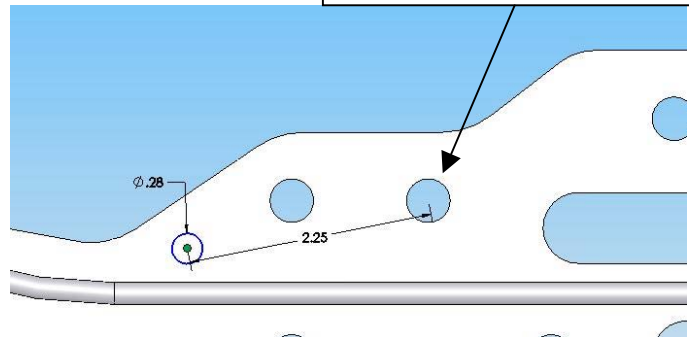

Arctic Cat M7

1. Drill a 3/8" hole 5/8" up from the upper rail-strengthening ridge and 1 3/8" back from the idler wheel hole.
2. Remove idler wheel and bracket.
3. Drill second hole 2 1/4" forward and slightly above the upper rail-strengthening ridge.
4. Saw bracket in half and use the lower half for a spacer
5. Reinstall lower half of idler wheel bracket using the original hardware.
6. Install ice scratchers using supplied hardware.

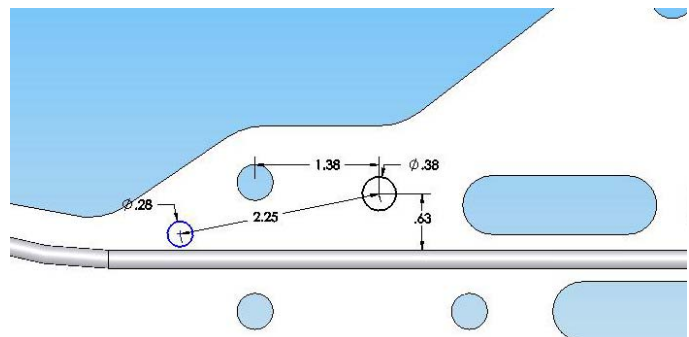

Yamaha RX1/Apex Mountain

1. Drill 3/8" hole back 1 5/8" from front torque arm mounting hole and up 5/8" from rail strengthening ridge.
2. Drill 9/32" hole 2 1/4" forward from first hole.
3. Install ice scratchers using supplied hardware.

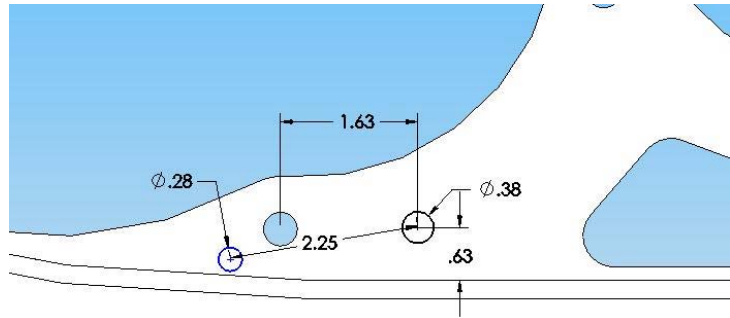

Any Model with HRP Suspension

1. Drill a 9/32" hole 2 1/4" in front of the forward most front torque-arm mounting hole.
2. Remove bolts at forward-most front torque-arm mounting hole.
3. Mount ice-scratchers in threaded shaft using the provided longer bolts.

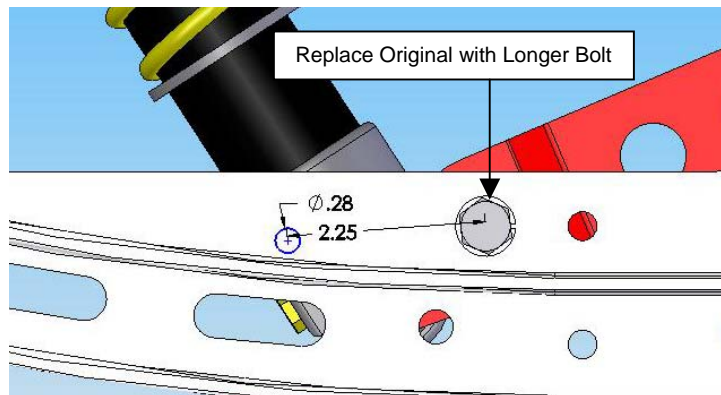

Generic Installation Instructions

The ice scratcher kit can be installed anywhere in the vicinity of the front track shock. The main ice scratcher mounting hole must be 3/8". The second hole, which the front of the spring keys into, needs to be 9/32" in diameter and 2 1/4" forward of the 3/8" hole. The front part of the spring should be horizontal to the hifax when installed. The ice scratcher should be mounted in such a way that the rear part of the spring can be pulled up and over the rail for storage. In this stored position the spring should not interfere with any moving parts of the suspension through full suspension travel. The snow kicked up by the scratchers should spray into the track and cooler at the rear of the sled.

A Note on Removing Idler Wheels

Some customers may not feel comfortable removing idler wheels. The idler wheels are designed to keep the track from wearing out the hifax too quickly due to heat and pressure. The ice scratchers lubricate and cool the hifax and track which makes the idler wheels unnecessary. Proper use of the ice scratchers will allow the hifax to last much longer than the idler wheels on their own. Any skid installed at the HRP shop will have the wheels removed. You may leave the idler wheels, but we recommend removing them.

WARNING: Raise scratchers for backing up and loading to avoid breakage.

Replacement springs are available from HRP. Replacement Springs Part Number:

Right Hand 12-193

Left Hand 12-194

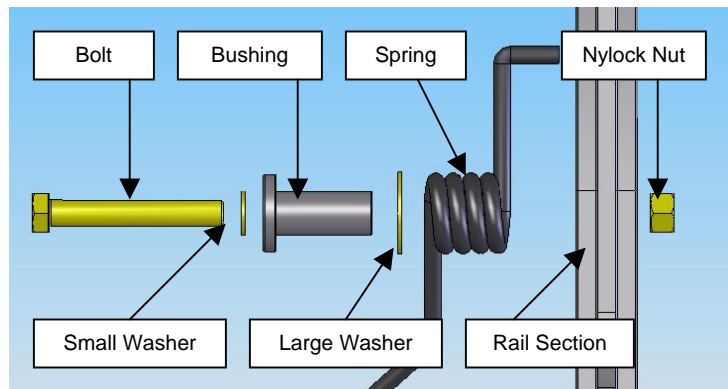

Limited Warranty

Due to the nature of this product being susceptible to damage from hitting rocks, bridges, loading ramps, trailer decks, etc., and snowmobiles with reverse **we cannot warranty scratcher springs**. Individual scratcher springs are available for replacement purposes. This warranty does not cover cosmetic or structural damage arising from abuse or misuse, owner neglect, improper installation and/or assembly, or improper maintenance. Any modifications, changes, additions, or substitutions to any part or component of HRP Ice Scratchers are done solely at the sole risk of the user. HRP makes no warranty against said modifications, changes, additions, or substitutions. Wear from normal use or exposure to environmental elements is not covered by this warranty. HRP makes no warranty against any incidental or consequential damage to snowmobile or parts, or rider injury caused by defects as covered in this warranty. There is no other remedy under this warranty, either express or implied. HRP is not responsible for any shipping or dealer charges related to any warranty claim, whether or not said claim is accepted by HRP.